



# Sketching Tips and Tricks

## Model Items, Hole series



Jochen Robert Fehse

# Introduction

---

- ▶ Why talk about Sketching??????????



# Introduction

---

- ▶ Why talk about Sketching??????????
- ▶ It's where it starts, and where you spend time.



# Basics

---

## ▶ Sketch element Colors

 Black Fully defined

 Blue under defined

 Yellow invalid

 Red not solved

 Dangling



# Sketching Arcs

---

- ▶ Tips and Tricks



## Line to arc switch

---

- ▶ Switch from Line to arc by returning the cursor to the start point of the current segment, or use the A key.



# Dimension Arc angle

---

- ▶ Click on the two end point then click on the center.

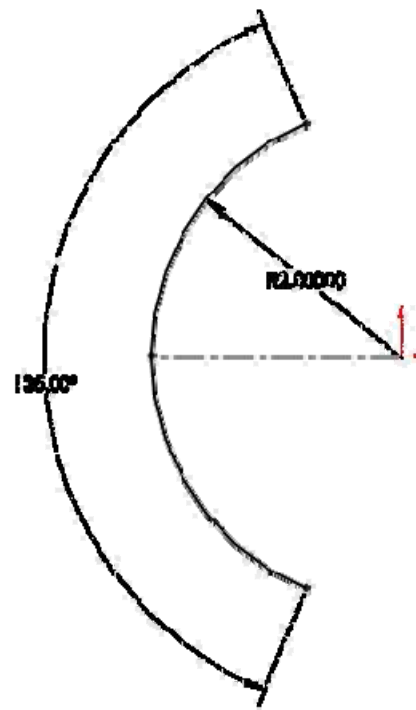

# Dimension Arc Length

---

- ▶ Click on the two end points then click on the arc line.

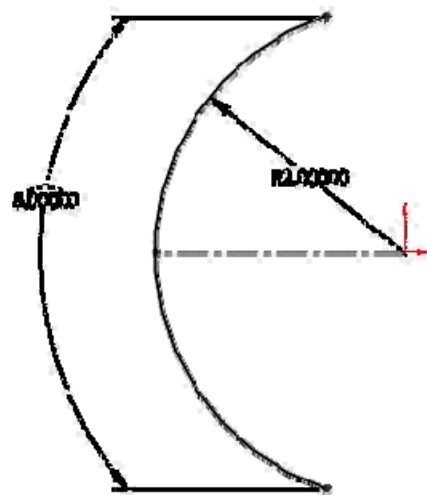

# Dimension to arc



- ▶ Dimension to arc perimeter by holding the shift key as you apply smart dimension.

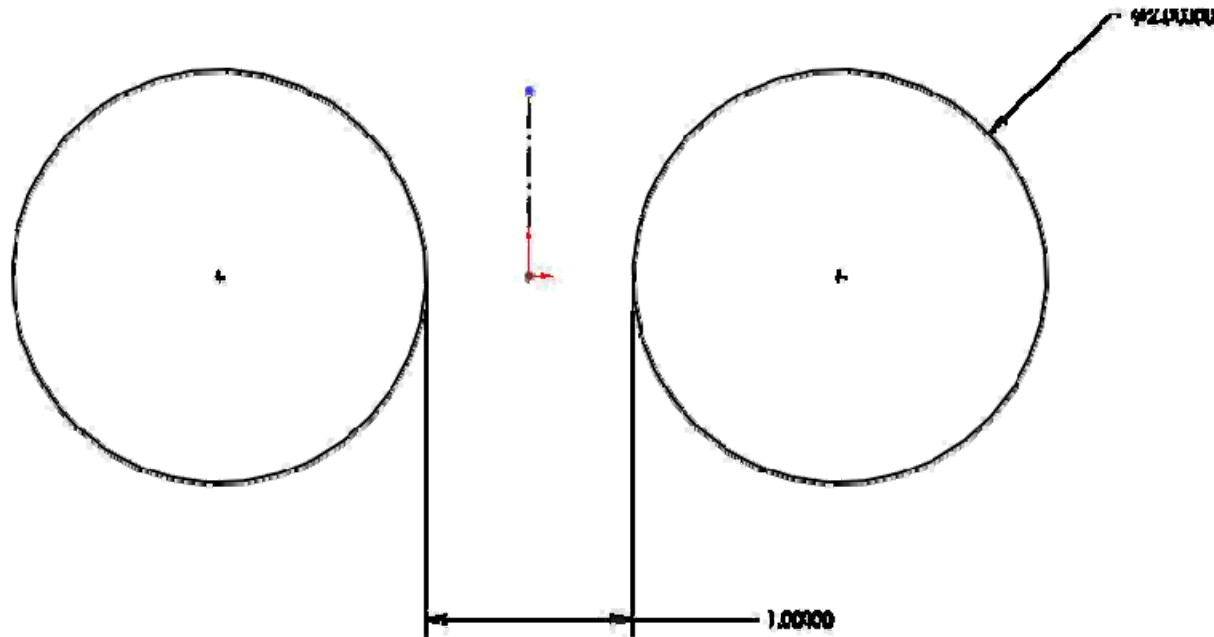

# Split entities

---

- ▶ Splitting entities as a way of editing, avoid deleting when possible.



# Separating Sketch entities

---

- ▶ Click on sketch segment while holding the CTRL key release CTRL before releasing the mouse button.
- ▶ Releasing the CTRL key before the mouse button will copy entity.



# Dragging sketch geometry

---

- ▶ Drag sketch geometry by the holding the shift key while dragging.



## Use the Sketch wizard

---

- ▶ To solve errors in complex sketches use the sketch wizard, view all the solutions before you decide.



# Create a Slot Sketch

---

- ▶ Create a slot by sketching a line select offset bidirectional and select cap ends (arc or line) select sketch line to be switched to construction if needed.
- ▶ Alternative slot creation. Thin Feature with fillet option, currently not available.



# Snaps

---

- ▶ When sketching on geometry (ASSY, or part) hold down CTRL to avoid snapping.



# Trim Tool

---

- ▶ Use the Trim tool to trim and extend.
- ▶ Extend lines by holding the shift key and dragging the sketch entity.



# Dynamic Mirror

---

Great for symmetrical concepts

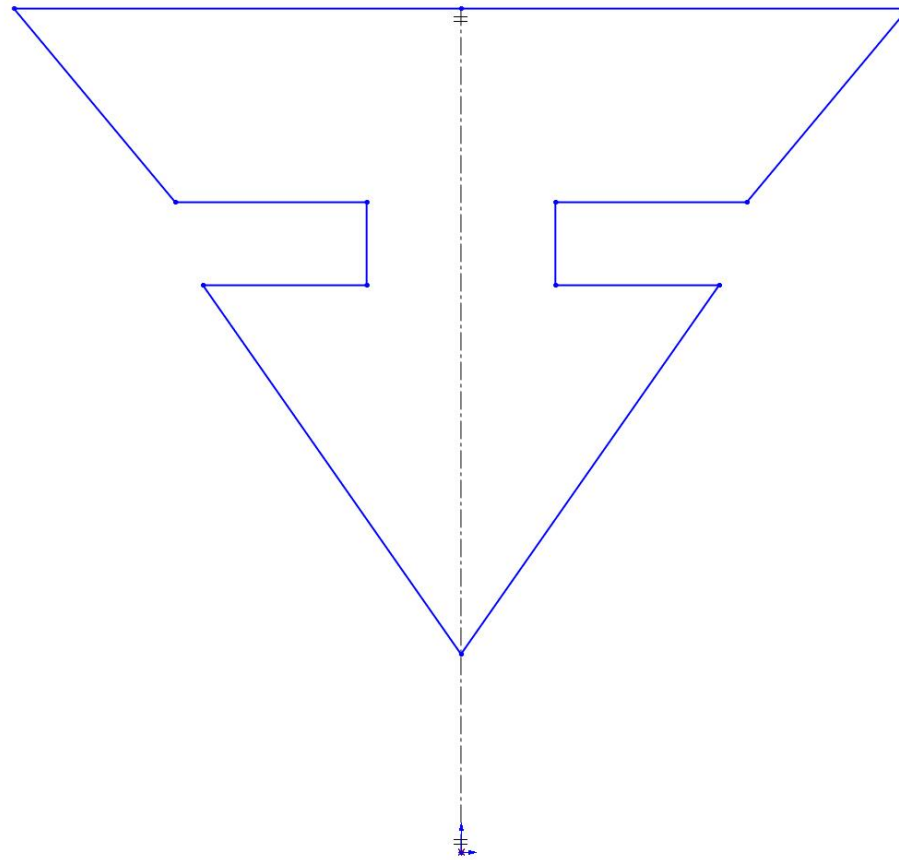

# Convert entities

---

- ▶ Convert entities by selecting a face and then clicking convert entities.
- ▶ Convert entities of part of a face by using sketch tool “close sketch to model”



# Configuration driven sketch relation

---

- ▶ You can vary sketch relations of the same entities using configurations.



# Reuse sketch dimensions

---

- ▶ Bring dimensions into the drawing.



# Creating a new part in an Assembly

---

- ▶ Create it by using the Top Down method (In context)
- ▶ Create it by using the Bottom up method (build part and bring it into the assembly.)
- ▶ I would like to show you my preferred method.



# Assembly feature Hole series

---

